

**RA 43|B 40
RA 55|B 40 iL**

**Ersatzteilliste
Reinigungsautomat**

**Spare parts list
Scrubber dryer**

**Catalogue des pièces de rechange
Auto-laveuse**

**Elenco pezzi di ricambio
Lavasciuga pavimenti**

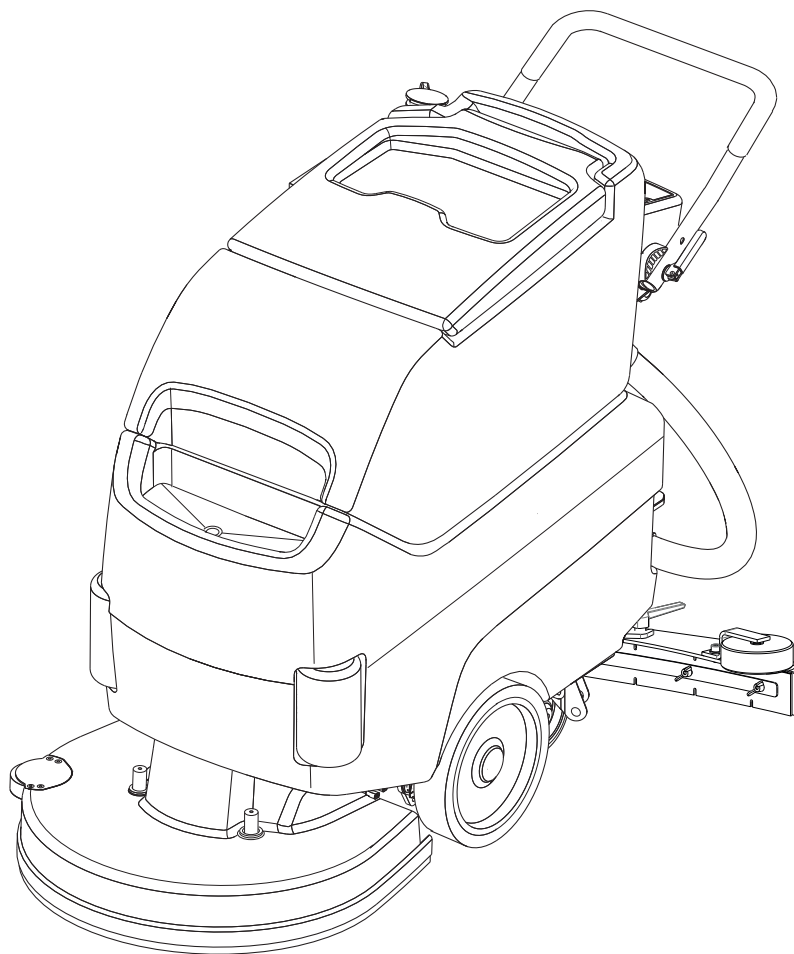

Frischwassertank B

Pos.	Art. Nr.	Stück	Bezeichnung	Description	Designation	Descrizione
1	21519200	1	FW-Fank, blau	solution tank, blue	Réservoir eau fraîche, bleu	serbatoio soluzione detergente, blu
	21519202		FW-Fank, weiß	solution tank, white	Réservoir eau fraîche, blanc	serbatoio soluzione detergente, bianco
2	21585100	1	FW-Ablaufschlauch PU	drain hose	Flexible de vidange	tubo scarico
3	20959400	1	Schlauschelle 9 W4 20-32	hose clamp	Support pour tuyau	fascetta tubo flessibile
4	21522300	2	Scharnier	hinge	charnière	cerniera
5	20011000	4	Zylinderschraube M 6x20 VA	cylindrical head screw M6x20	Vis cylindrique M6x20	vite M6x20
6	20000700	4	Scheibe 6,4x12,0x1,5 VA	washer 6,4	Rondelle 6,4	rondella 6,4
7	21053400	1	Platte Gurtband	plate	Plaque	piastra
8	51058200	0,5	Gurtband 30mm	strap	sangle	banda tessile
9	21062100	1	Zylinderstift 6x30 VA	pin 6x30	Goupille 6x30	spinotto cilindrico 6x30
10	21039800	2	Senkschraube M 5x16 schw	countersunk M5x16	Vis à tête noyée M5x16	vite M5x16
11	21032801	2	Abweisrolle FW-Tank	protecting caster	Roulette de protection	ruota di protezione
12	21032900	2	Achse f.Abweisrolle	axle	Axe	asse
13	20622600	2	Scheibe 13,0x24,0x2,5 PA	washer 13x24x2,5	Rondelle 13x24x2,5	rondella 13x24x2,5
14	21033500	1	FW-Sieb	solution filter	Filtre eau fraîche	filtro soluzione detergente
15	21523200	1	Bedienplatte B	control element	Panneau de réglage	pannello di comando
	71002700	1	Aufkleber Bedienfeld B	label	Autocollant	etichetta
16	20369100	1	Rückfahrknopf	button	Bouton	manopola
17	20616000	1	Schutzkappe f.Rückfahrkn.	protection cover	Capuchon de protection	coperchio di protezione
18	20816200	6	Schraube KA 50x16 EJ schw	screw KA 50x16	Vis KA 50x16	vite KA 50x16
19	21521100	1	Stange FW-Dosierung L=475	bar	Tige	barra
20	20647100	1	Zeigerknopf f.Wasserdosier	index button	Boutton	manopola indicatore
21	20927800	1	Gewindestift M5x 8 VA	headless screw M5x8	Goupille filetée M5x8	spina filetata M5x8
22	20069200	1	Sicherungsscheibe VZ5 VA	washer 5	Rondelle 5	rondella 5
23	20000700	1	Scheibe 6,4x12,0x1,5 VA	washer 6,4	Rondelle 6,4	rondella 6,4
24	21585300	1	Kabelhalter	cable holder	Support cable	supporto cavo
25	20958800	1	Microschalter 1006.1514-02	microswitch	Microcommutateur	microinterruttore
26	20018400	2	Linsenschraube M 3x16 VA	screw M 3x16	Vis à tête bombée M3x16	vite M 3x16
27	20982101	1	Batteriewächter+Zubehör	Battery monitor	Indicateur de charge batteries	Controllo batterie
28	20892400	1	Wippschalter m.Schutzkappe	swich	interrupteur	interruttore
30	21541100	1	Batteriekabel ext. LG	battery cable	Câble	cavo
31	21541000	1	Batterie-Ladekabel ext. LG	battery charging cable	Câble	cavo di carica batteria
32	21540100	1	Batteriekabel iL	battery cable onboard charger	Câble	cavo
33	21387800	1	Sicherungshalter	fuse holder	Support fusible	supporto fusibile
34	21387900	1	Streifensicherung 100 A	fuse 100A	Fusible 100A	inserto fusibile
35	21387300	1	Batterie-Verbindungskabel	batteries connection cable	Câble	cavo collegamento - batterie
36	21571100	1	Anschlag Batterien	battery fixing bracket	support de fixation de batteries	staffa di fissaggio per le batterie

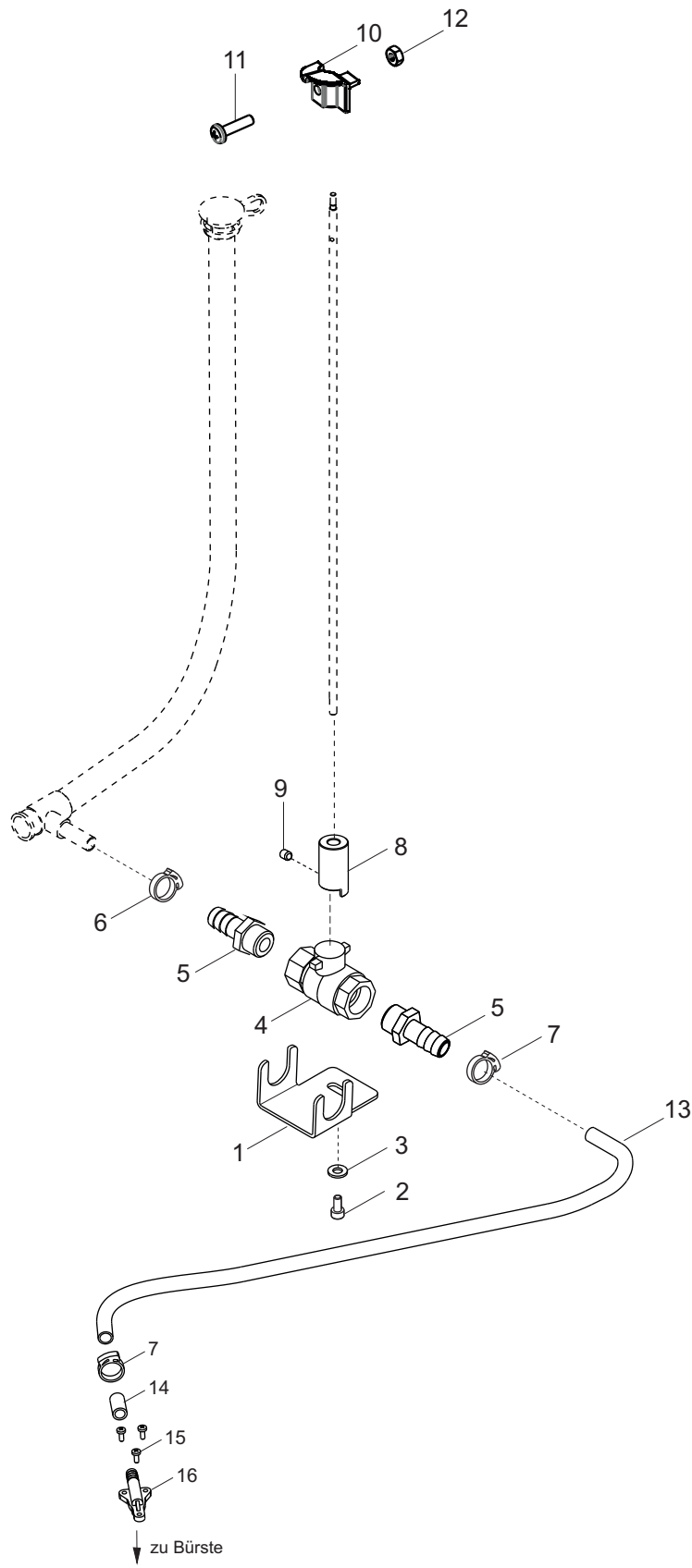

Wasserführung B

Pos.	Art. Nr.	Stück	Bezeichnung	Description	Designation	Descrizione
1	21522100	1	Ventilhalter	valve holder	support pour valve	supporto valvola
2	20730900	1	Zylinderschraube M5x10 VA	cylindrical head screw M5x10	Vis cylindrique M5x10	vite M5x10
3	20183000	1	Scheibe 5,3x15,0x1,4 VA	washer 5,3	Rondelle 5,3	rondella 5,3
4	21033200	1	Kugelhahn 3/8"-D10	ball cock	robinet à bille	rubinetto dell'acqua
5	20681400	2	Schlauchtülle 3/8"	hose clamp	Collier	fascetta per tubi flessibili
6	20628400	1	Schlauchklemme D15-17,2	hose clamp	Support pour tuyau	fascetta tubo flessibile
7	20596500	3	Schlauchklemme D17-18,5	hose clamp	Support pour tuyau	fascetta tubo flessibile
8	21033303	1	Kupplung mit Anschlag	attachment	Couplage	giunto
9	20404000	2	Gewindestift M6x8 VA	headless screw M6x8	Goupille filetée M6x8	spina filetata M6x8
10	20892100	1	Schaltnocken	cam	cane de contact	camma
11	20182600	1	Linsenschraube M 4x16 VA	lens screw M4x16	Vis à tête bombée M4x16	vite M4x16
12	20002600	1	6-Kantmutter M 4	hex.nut M4	Ecrou hexagonal M4	dado essag.M4
13	50020600	0,760 m	Schlauch D13x3 mit Drahtspirale	hose	Tuyau	tubo flessibile
14	50046800	0,03	Schlauch	hose	Tuyau	tubo flessibile
15	21571300	3	Linsenschraube M 4x10	screw M4x20	Vis M4x20	vite M4x20
16	21515200	1	Anschlussstück	hose clamp	Support pour tuyau	fascetta tubo flessibile

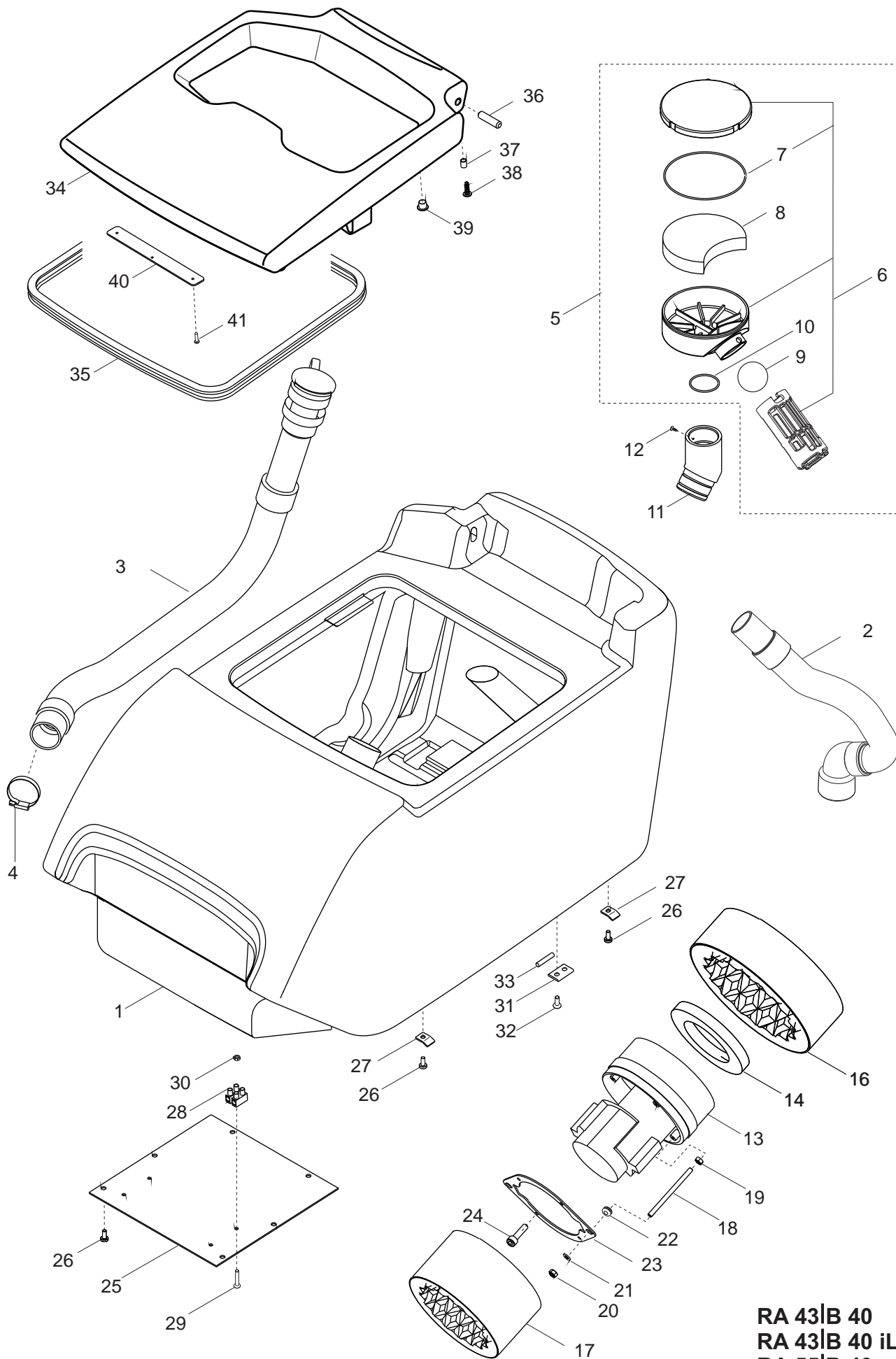

columbus

RA 43|B 40
 RA 43|B 40 iL
 RA 55|B 40
 RA 55|B 40 iL

Schmutzwassertank

Pos.	Art. Nr.	Stück	Bezeichnung	Description	Designation	Descrizione
1	21519400	1	SW-Tank, blau	recovery tank,blue	Réservoir de récupération, bleu	serbatoio soluzione di recupero, blu
	21519402		SW-Tank, weiß	recovery tank, white	Réservoir de récupération, blanc	serbatoio soluzione di recupero, bianco
2	20643631	1	Saugschlauch NW38 L=770	suction hose	Flexible d'aspiration	tubo aspiratore
3	21585000	1	SW-Ablaufschlauch PU L660	drain hose	Tuyau de vidange	tubo di scarico
4	20219700	1	Schlauchschele W4 32-50/9	hose clamp	Collier	fascetta per tubi flessibili
5	21058837	1	Prefilter und Schwimmer	prefilter-floater	Préfiltre-floteur	prefiltro-galleggiante
6	21584430	1	Prefiltertopf kpl.	suction box	Pot d'aspiration	vaso aspirante
7	21075201	1	Rundschnurdichtung	seal	Garniture	guarnizione
8	21061600	1	Prefilter	prefilter	Préfiltre	prefiltro
9	21058900	1	Ball Ø40	ball	Balle	palla
10	20063400	2	O-Ring 25x2	O-ring	Garniture	guarnizione
11	21059000	1	Fitting 63°	fitting 63°	coude 63°	fitting
12	20048300	2	Blechschr.Li C 2,9x6,5 VA	screw	Vis	vite
13	21520100	1	Saugmotor 24/400 2-stuf	suction motor	Moteur à aspiration	motore aspirazione
14	20808600	1	Dichtscheibe D155	gasket	Joint	guarnizione
16	21522400	1	Schalldämmung Turbine	sound insulation	Amortisseur de bruit	isolamento acustico
17	21522500	1	Schalldämmung Motor	sound insulation	Amortisseur de bruit	isolamento acustico
18	21038401	2	Gewindestift M6x90 VA	threaded bolt	Tige filetée	perno filettato
19	20002000	2	6-Kantmutter M 6 VZD	hex.nut M6	Ecrou hexagonal M6	dado essag.M6
20	20070000	2	6-Kantmutter M 6 stop	hex.nut M6 stop	Ecrou hexagonal M6 stop	dado essag.M6 stop
21	20000700	2	Scheibe 6,4x12,0x1,5 VA	washer 6,4	Rondelle 6,4	rondella 6,4
22	21161900	2	Durchführungsstülle PVC	grommet	Douille	passacavo
23	21523400	1	Halter Saugmotor	Support suction motor	Support Moteur à aspiration	supporto motore aspirazione
24	20625300	4	Schraube KA 50x12 EJ schw	screw KA 50x12	Vis KA 50x12	vite KA 50x12
25	21522600	1	Saugmotorabdeckung	motor cover	Couvercle de brosse	copertura
26	20193000	8	Zylinderschraube M 6x10 vz	cylindrical head screw M6x10	Vis cylindrique M6x10	vite M6x10
27	21523801	2	Gelenkriegel	pedal lock	Verrou	chiavistello
28	20409200	1	Klemmleiste 2-polig 4mm²	clamping strip 2-pol	Borne de jonction 2-pol	presa 2-pol
29	21157300	1	Linsenschraube M 4x20 VA	screw M4x20	Vis M4x20	vite M4x20
30	20007101	1	6-Kantmutter M 4 stop A4	hex.nut	Ecrou hexagonal	dado essag.
31	21053400	1	Platte Gurtband	plate	Plaque	piastra
32	20636900	2	Senkschraube M 6x12 VA	countersunk M6x12	Vis à tête noyée M6x12	vite M6x12
33	21062100	1	Zylinderstift 6x30 VA	pin 6x30	Goupille 6x30	spinotto cilindrico 6x30
34	21519300	1	Deckel SW-Tank, grau	tank cover, grey	Couvercle,gris	coperchio, grigio
	21519302		Deckel SW-Tank, weiß	tank cover, white	Couvercle, blanc	coperchio, bianco
35	50798500	1,29	Dichtprofil 8564/00M001	band sealer	Joint	profilato di tenuta
36	20978400	2	Deckelbolzen L39	lid bolt	Boulon	bullone
37	20938300	1	Distanzstück	spacer	Pièce d'écartement	distanziale
38	20816200	1	Schraube KA 50x16 EJ schw	screw KA 50x16	Vis KA 50x16	vite KA 50x16
39	20035400	1	Stopfen D10,7	cover	Capot	tappo
40	20899200	1	Leiste f.Luftumlenkung	ledge	Listeau	lardone
41	20828800	3	Blechschr.Li C 3,5x13 VA	screw 3,5x13	Vis 3,5x13	vite 3,5x13

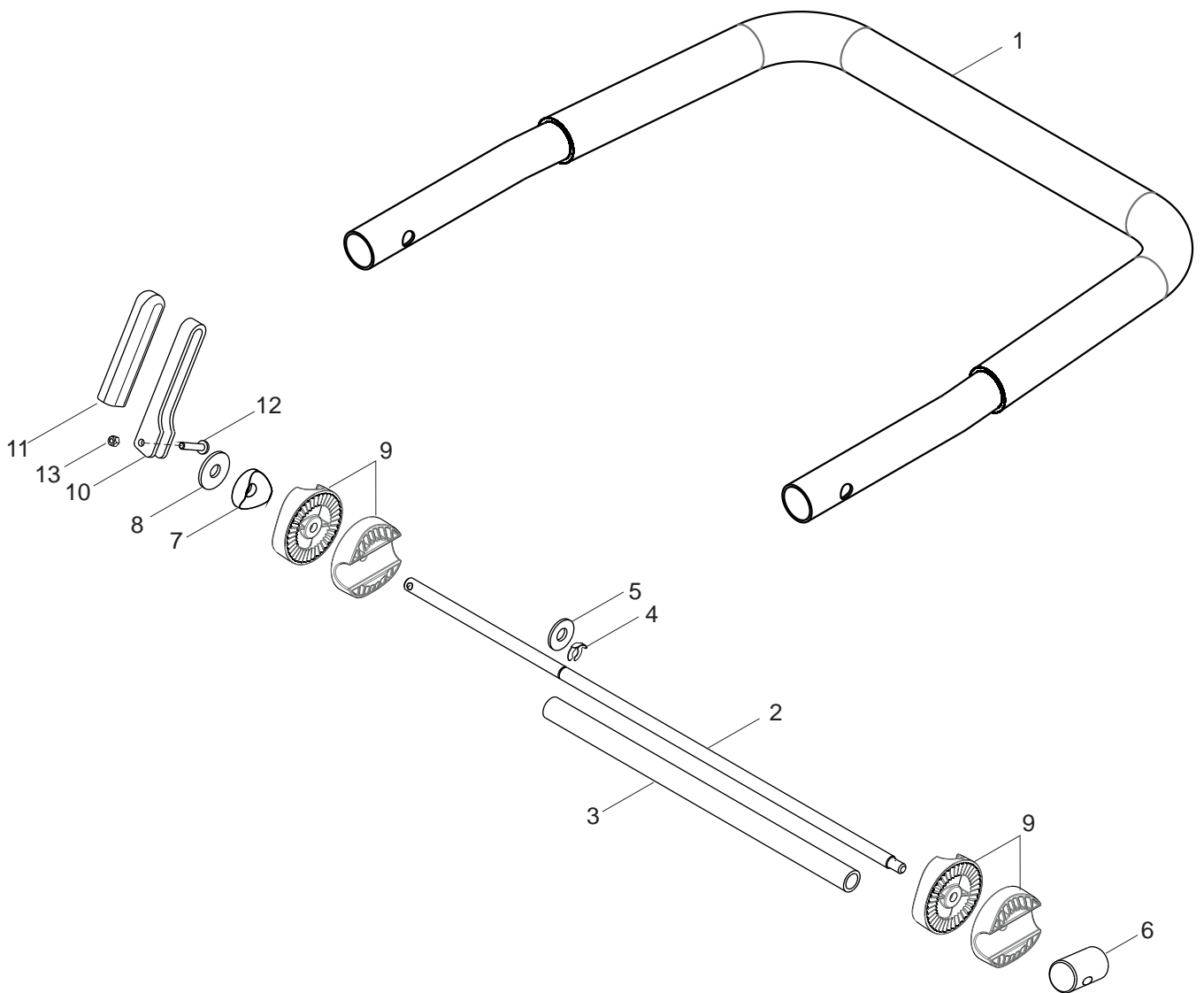

Griffbügel B

Pos.	Art. Nr.	Stück	Bezeichnung	Description	Designation	Descrizione
1	21522730	1	Griffbügel B kpl	handle B	Poignée B	manico B
2	21523100	1	Griffstange	handle bar	Barre	barra
3	50046800	0,250 m	Schlauch f. Griffstange	hose	Tube	tubo
4	21544600	1	KL-Sicherung 8	safety piece 8	Collier d'épaulement 8	piece di sicurezza 8
5	20706900	1	Scheibe 8,4x17x2 PA	washer	Rondelle	rondella
6	21528500	1	Mutter Griff	nut	Ecrou	dado
7	21523000	1	Sattelscheibe	special washer	Rondelle	rondella speciale
8	20633700	1	Scheibe 8,4x24x2	washer	Rondelle	rondella
9	20935800	4	Griffplatte	catch	Arrêt	attacco
10	21523700	1	Excenterhebel	lever	Levier	leva
11	21528700	1	Überzug	overlay	revêtement	rivestimento
12	21157300	1	Linsenschraube M4x20	lens screw	vis	vite
13	20007101	1	6-Kt Mutter M4 stop	hex. nut	Ecrou hexagonal	dado esagonale

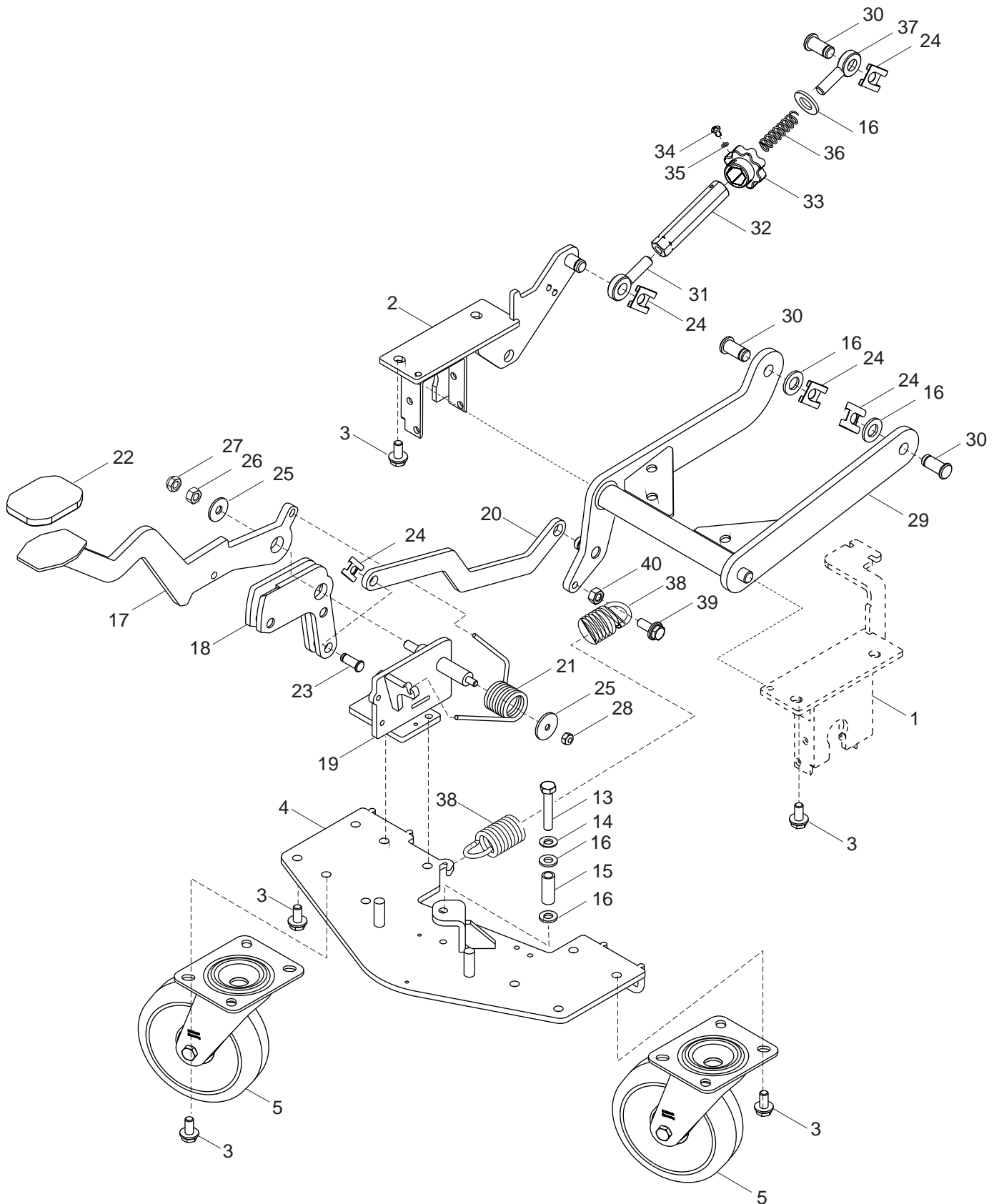

RA 43|B 40
 RA 43|B 40 iL
 RA 55|B 40
 RA 55|B 40 iL

Mechanik

Pos.	Art. Nr.	Stück	Bezeichnung	Description	Designation	Descrizione
1	21520200	1	Radhalter li.	wheel holder, left	Support de roue, gauche	supporto per ruota, sinistro
2	21520300	1	Radhalter re.	wheel holder, right	Support de roue, droit	supporto per ruota, destro
3	20682200	14	Vebrusschraube M8x16	hex.screw	Vis à tête hex.	vite
4	21520400	1	Traverse	traverse	Traverse	attraversa
5	21520000	2	Lenkrolle D125x35	caster Ø125	Poulie-guide Ø125	rullo di guida Ø125
13	20191700	1	6-Kantschraube M 8x45 VA	hex.screw	Vis à tête hex.	vite
14	20067600	1	Scheibe 8,4x16,0x1,6 VA	washer	Rondelle	rondella
15	21522200	1	Distanzhülse 12x8,5x30	spacer sleeve	Douille d'écartement	boccola distanziale
16	20622600	3	Scheibe 13,0x24,0x2,5 PA	washer	Rondelle	rondella
17	21521401	1	Fußpedal	pedal	Pédale	pedale
18	21528300	1	Pedalführung	pedal guidance	Guide pédale	guida pedale
19	21521501	1	Pedalhalter	pedal holder	Support pédale	supporto pedale
20	21521200	1	Schubstange 40	pushbar	Barre	asta
21	21585200	1	Schenkelfeder	spring	Ressort	molla
22	20816000	1	Pedalgummi	rubber	Chaouchouc	gomma pedale
23	20642000	1	Bolzen mit Kopf	bolt Ø12	Boulon Ø12	bullone Ø12
24	20373800	5	SL-Sicherung 12	safety piece 12	Collier d'épaulement 12	piece di sicurezza 12
25	20633700	1	Scheibe 8,4x24,0x2,0 VA	washer	Rondelle	rondella
26	20000500	1	6-Kantmutter M 8	hex. nut	Ecrou hexagonal	dado esagonale
27	20280500	1	6-Kantmutter M 8 stop	hex. nut	Ecrou hexagonal	dado esagonale
28	20070000	1	6-Kantmutter M 6 stop	hex. nut	Ecrou hexagonal	dado esagonale
25	20633700	1	Scheibe 8,4x24,0x2,0 VA	washer	Rondelle	rondella
29	21520500	1	Hebegabel	lifting fork	Levier	forcella sollevamento
30	20650100	3	Bolzen mit Kopf	bolt Ø12	Boulon Ø12	bullone Ø12
31	21035200	1	Aufnahme li	receiver, left	Logement	supporto
32	20628003	1	Spannschloßmutter M10x90	barrel nut M10	Ecrou de tension M10	dado tenditore M10
33	21047400	1	Sterngriff SW17	Star grip	Poignée-étoile	Manopola di chiusura
34	20003200	1	Linsenschraube M 5x 8 VA	lens screw	Vis à tête bombée	vite
35	20009600	1	Scheibe 5,3x10,0x1,0	washer	Rondelle	rondella
36	21251500	1	Druckfeder VD-217C	spring	Resort	molla di pressione
37	21035300	1	Aufnahme re	receiver, right	Logement	supporto
38	20670500	1	Zugfeder RZ-162U-20I	extension spring	Ressort	molla di trazione
39	20195300	1	Verbusschraube M 8x20	hex.screw	Vis à tête hex.	vite
40	20000500	1	6-Kantmutter M 8	hex. nut	Ecrou hexagonal	dado esagonale

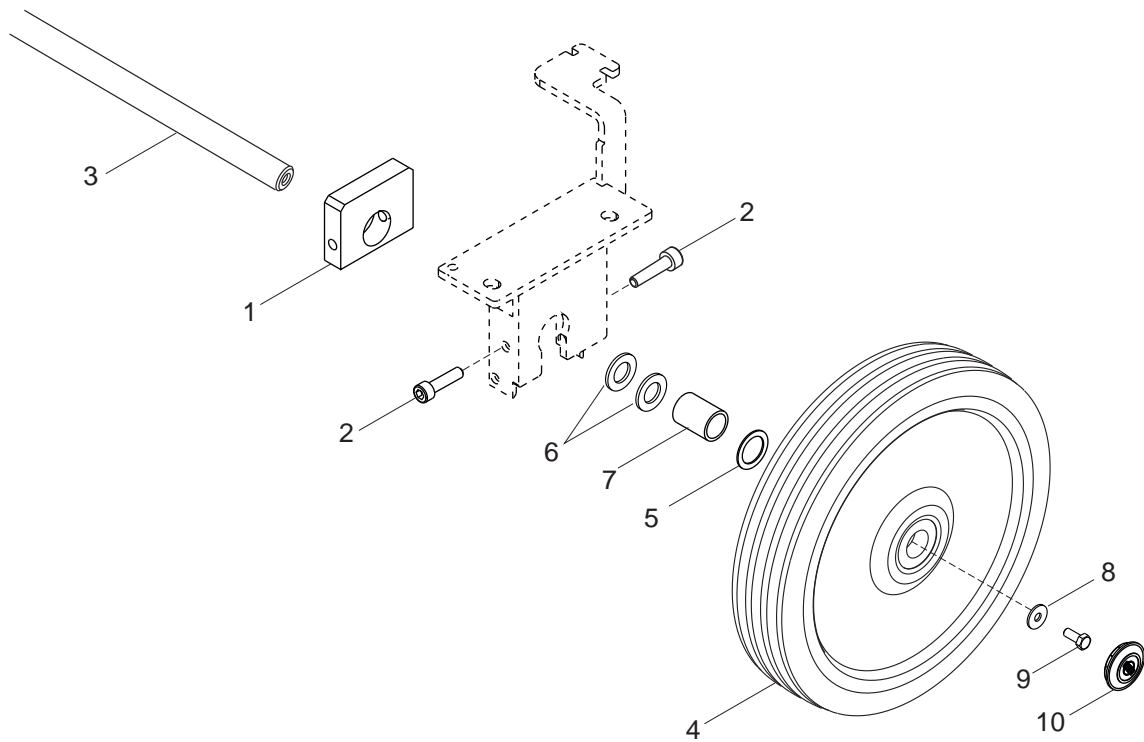

Radeinheit B

Pos.	Art. Nr.	Stück	Bezeichnung	Description	Designation	Descrizione
1	21034300	2	Achshalter	axle holder		
2	20279200	4	Zylinderschraube M 6x16 VA	screw M 6x16	Vis cylindrique M 6x16	vite M 6x16
3	20936200	1	Radachse	wheel axle	Axe de roue	perno ruota
4	21022901	2	Rad D250x20x50 PP-Felge	wheel Ø250	Roue Ø250	ruota Ø250
5	20024100	2	Pass-Scheibe 20x28x1,0 VA	locating disc 20x28x1	Rondelle 20x28x1	rondella 20x28x1
6	20938500	4	Scheibe 21x37x3 PA	washer 21x37x3	Rondelle 21x37x3	rondella 21x37x3
7	20972602	2	Distanzhülse 25x20x33,5	spacer sleeve 25x20x33,5	Douille d'écartement 25x20x33,5	boccola distanziale 25x20x33,5
8	20277800	2	Scheibe 9x28x3 VA	washer 9x28x3	Rondelle 9x28x3	rondella 9x28x3
9	20068001	2	6-Kantschraube M 8x20 VA	hexagon screw M8x20	Vis à tête hex. M8x20	vite esagonale M8x20
10	20521600	2	Zierkappe	cover	Cache	coperchio

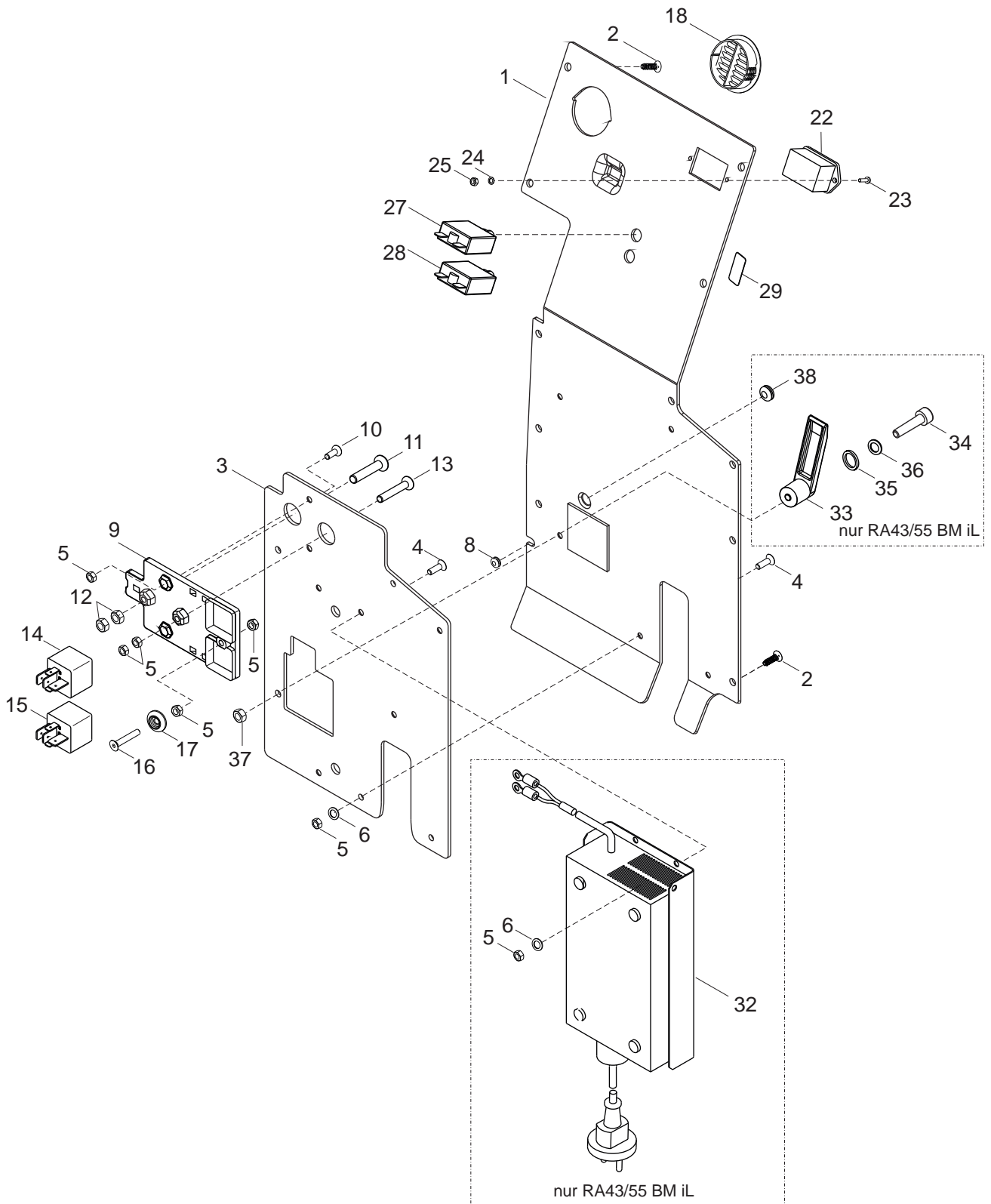

Elektrik B

Pos.	Art. Nr.	Stück	Bezeichnung	Description	Designation	Descrizione
1	21536800	1	Rückwand B Q	rear wall	Paroi arrière	parete posteriore
2	20816200	11	Schraube KA 50x16 EJ schw.	vite KA M5x16	Vis KA M5x16	vite KA M5x16
3	21534900	1	Kühlblech	cooling tin	dissipateur	dissipatore
4	21039800	3	Senkschraube M 5x16 schw	countersunk M5x16	Vis à tête noyée M5x16	vite M5x16
5	20574300	9	6-Kantmutter M 5 VA	hex. nut M 5	Ecrou M5	dado essag. M5
6	20067400	3	Sicherungsscheibe SMZ 5	lock washer SMZ5	Rondelle de sécurit. SMZ5	anello d'arresto SMZ5
8	21161900	1	Durchführungstülle	grommet	Douille	passacavo
9	21535500	1	Halteplatte Relais	plate for relay	Plaque pour relais	piastra per relé
10	20162300	2	Senkschraube M 5x10 VA	countersunk M5x10	Vis à tête noyée M5x10	vite M5x10
11	20116400	1	6-Kt Schraube M6x20	hexagon screw M6x20	Vis à tête hex.M6x20	vite esagonale M6x20
12	20002000	2	6-Kantmutter M 6 VA	hex. nut M 6	Ecrou M6	dado essag. M6
13	20102300	1	6-Kt Schraube M5x20	hexagon screw M5x20	Vis à tête hex.M5x20	vite esagonale M5x20
14	21452330	1	Relais klein mit 2 Kabeln	relay	Relais	relè
15	21452331	1	Relais klein mit 3 Kabeln	relay	Relais	relè
16	21155900	1	Senkschraube M 5x30 schw.	countersunk M5x30	Vis à tête noyée M5x30	vite M5x30
17	21154900	1	Rosettenring 5,3 PA	washer	Rondelle	rondella
18	21585600	1	Luftgitter Ø50	ventilation grille	grille d'aération	griglia di ventilazione
22	21168200	1	Betriebsstundenzähler digital	Counter of operating h	Compteur horaire	Contatore
23	20041800	2	Linsenschraube M3x10 VA	screw M3x10	Vis M3x10	vite M3x10
24	20165400	2	Sicherungsscheibe SMZ 3 vz	lock washer SMZ 3	Rondelle de sécurit. SMZ 3	anello d'arresto SMZ 3
25	20011500	2	6-Kantmutter M 3 vz	hex. nut M 3	Ecrou M 3	dado essag. M 3
27	20567100	1	Überstromschutzsch.20A	fuse 20A	Fusible 20A	fusibile 20A
28	20202401	1	Überstromschutzsch.30A	fuse 30A	Fusible 30A	fusibile 30A
29	70117000	1	Aufkleber Sicherung 2-fach	sticker	Autocollant	etichetta
32	20891104	1	Ladegerät onboard 13A 76Ah5	batterie charger 13A 76Ah5	Chargeur 13A 76Ah5	caricabatteria 13A 76Ah5
	20891114	1	Ladegerät onboard 13A-105Ah5	batterie charger 13A 105Ah5	Chargeur 13A 105Ah5	caricabatteria 13A 105Ah5
4	21039800	2	Senkschraube M 5x16 schw	countersunk M5x16	Vis à tête noyée M5x16	vite M5x16
5	20574300	2	6-Kantmutter M 5 VA	hex. nut M 5	Ecrou M5	dado essag. M5
6	20067400	2	Sicherungsscheibe SMZ 5	lock washer SMZ5	Rondelle de sécurit. SMZ5	anello d'arresto SMZ5
33	20319600	2	Kabelhaken	cable hook	crochet pour câble	gancio
34	20831600	2	Zylinderschraube M 6x35 VA	screw M 6x35	Vis cylindrique M 6x35	vite M 6x35
35	20930900	2	O-Ring 8,5x1,5	O-ring	Joint ronde	guarnizione
36	20000700	2	Scheibe 6,4x12,0x1,5 VA	washer 6,4	Rondelle 6,4	rondella 6,4
37	20070000	2	6-Kantmutter M 6 stop	hex. nut M 6	Ecrou M6	dado essag. M6
38	21515500	1	Durchführungstülle geschlossen	grommet	Douille	passacavo

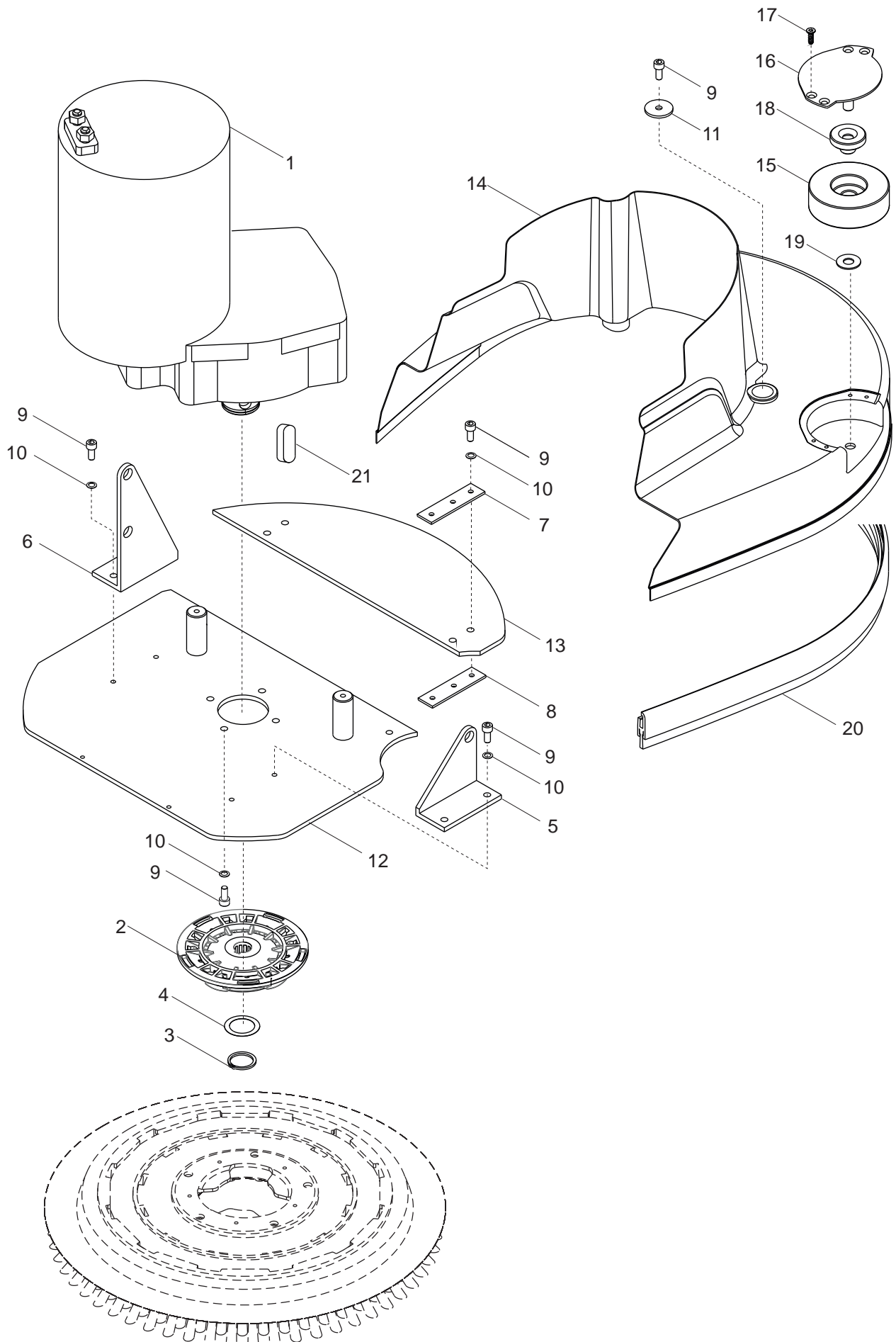

Bürsteinheit 43 B

Pos.	Art. Nr.	Stück	Bezeichnung	Description	Designation	Descrizione
	21524630	1	Bürsteinheit 43 B kpl. ERSATZ	Brush drive 43 B	Moteur brosse 43 B	Motore spazzola 43 B
1	21387001	1	Bürstenmotor 550W 24V V2A	brushbmotor 550W 24V	Moteur de brosse 550W 24V	motore 550W 24V
2	21291100	1	Bürsttaufnahme li.grau	Brush holder, grey	Support pour brosse, gris	Supporto spazzola, grigio
3	21057700	1	Sicherungsring AS 25x2 VA	circlip AS 25x2	Rondelle de sécurité AS 25x2	anello d'arresto AS 25x2
4	21045700	1	Pass-Scheibe 25x35x0,2 VA	Pass-Scheibe 25x35x0,2	shim ring	Rondelle d'ajustage
5	21522000	1	Bürstwinkel rechts	angle, right	Angle droite	angolo
6	21521000	1	Bürstwinkel links	angle, left	Angle gauche	angolo
7	21520800	2	Lasche oben	plate above	Platte dessus	linguetta sotto
8	21520900	2	Lasche unten	plate below	Platte au-dessus	linguetta sopra
9	20567500	16	Zylinderschraube M6x14 VA	cylindrical head screw M6x14	Vis cylindrique M6x14	vite M6x14
10	20008000	14	Sicherungsscheibe SMZ 6 vz	lock washer SMZ 6	Rondelle de securité SMZ 6	rondella di sicurezza SMZ 6
11	20191100	2	Scheibe 6,5x28,0x2,5 VA	washer 6,4	Rondelle 6,4	rondella 6,4
12	21523500	1	Bürstplatte 43	supported slab for brush 43	plaque de support de la brosse 43	piastra 43
13	21523600	1	Stoßplatte 43	plate	Platte	lamiera
14	21519500	1	Bürstabdeckung 43	brush cover 43	Couverture de brosse 43	copertura 43
15	21053700	1	Abweisrolle D80	protecting caster Ø80	Roulette de protection Ø80	ruota di protezione Ø80
16	21057800	1	Platte Abweisrolle	plate	Plaque	piastra
17	20681900	4	Schraube 52005TXVS516 schw	screw 5x16	Vis 5x16	vite 5x16
18	21054600	1	Führungsstopfen	bolt	Boulon	bullone
19	20054500	1	Scheibe 10,5x18x1,4	washer 10,5	Rondelle 10,5	rondella 10,5
20	21051100	1	Halteprofil+Bürstenstreifen	brush strip	Bande de protection balai	striscia spazzola con supporto
21	21057600	1	Passfeder 8x7x30 VA	featherkey	Ressort d'ajustage	linguetta di aggiustamento

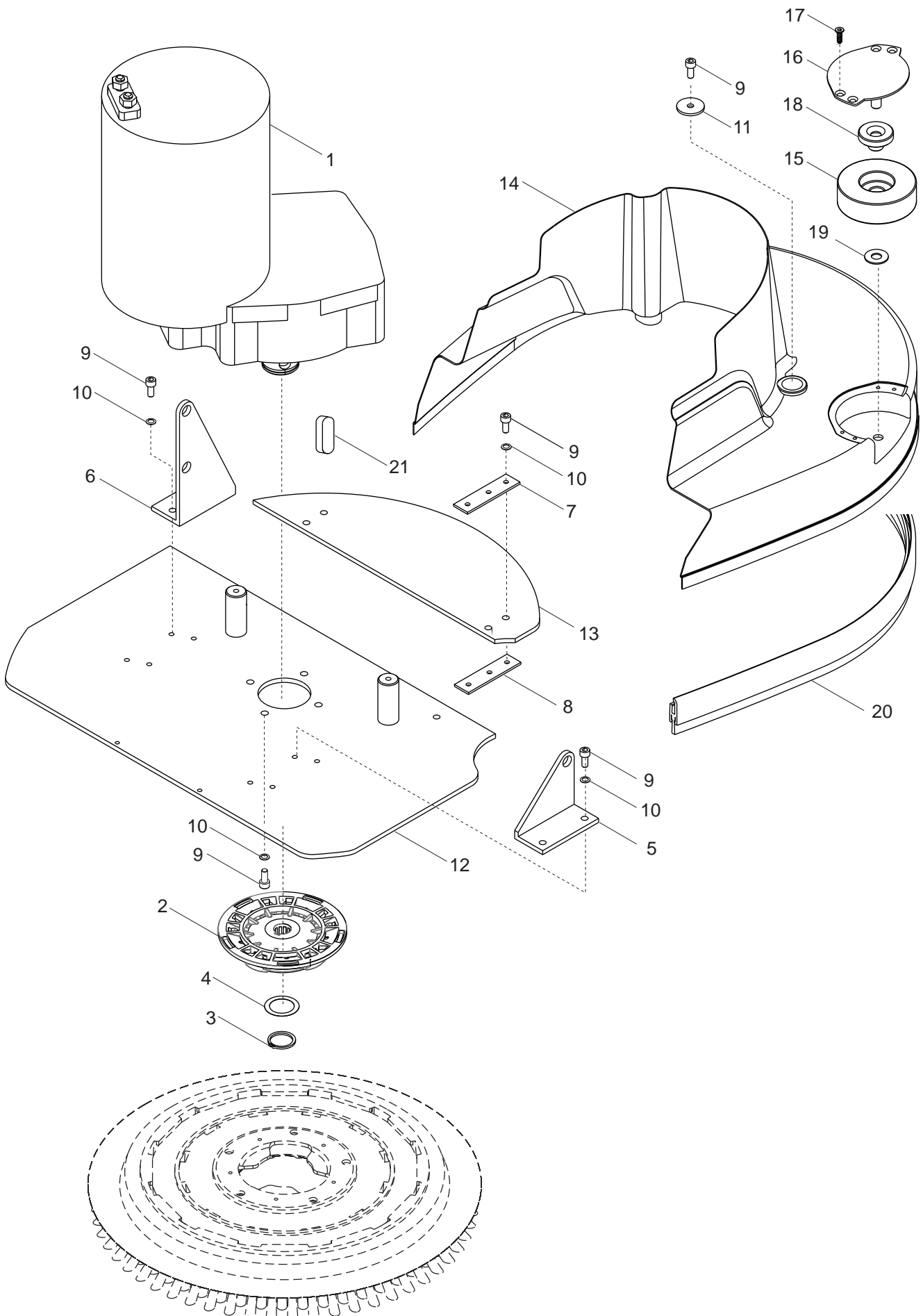

Bürsteinheit 55 B

Pos.	Art. Nr.	Stück	Bezeichnung	Description	Designation	Descrizione
	21524730	1	Bürsteinheit 55 B kpl. ERSATZ	Brush drive 55 B	Moteur brosse 55 B	Motore spazzola 55 B
1	21387001	1	Bürstenmotor 550W 24V V2A	brushbmotor 550W 24V	Moteur de brosse 550W 24V	motore 550W 24V
2	21291100	1	Bürsttaufnahme li.grau	Brush holder, grey	Support pour brosse, gris	Supporto spazzola, grigio
3	21057700	1	Sicherungsring AS 25x2 VA	circlip AS 25x2	Rondelle de sécurité AS 25x2	anello d'arresto AS 25x2
4	21045700	1	Pass-Scheibe 25x35x0,2 VA	Pass-Scheibe 25x35x0,2	shim ring	Rondelle d'ajustage
5	21522000	1	Bürstwinkel rechts	angle, right	Angle droite	angolo
6	21521000	1	Bürstwinkel links	angle, left	Angle gauche	angolo
7	21520800	2	Lasche oben	plate above	Platte dessus	linguetta sotto
8	21520900	2	Lasche unten	plate below	Platte au-dessus	linguetta sopra
9	20567500	16	Zylinderschraube M6x14 VA	cylindrical head screw M6x14	Vis cylindrique M6x14	vite M6x14
10	20008000	14	Sicherungsscheibe SMZ 6 vz	lock washer SMZ 6	Rondelle de securité SMZ 6	rondella di sicurezza SMZ 6
11	20191100	2	Scheibe 6,5x28,0x2,5 VA	washer 6,4	Rondelle 6,4	rondella 6,4
12	21520600	1	Bürstplatte 55	supported slab for brush 55	plaque de support de la brosse 55	supporto 55
13	21520700	1	Stoßplatte 55	plate 55	Platte 55	piastra 55
14	21519600	1	Bürstabdeckung 55	brush cover 55	Couverture de brosse 55	copertura 55
15	21053700	1	Abweisrolle D80	protecting caster Ø80	Roulette de protection Ø80	ruota di protezione Ø80
16	21057800	1	Platte Abweisrolle	plate	Plaque	piastra
17	20681900	4	Schraube 52005TXVS516 schw	screw 5x16	Vis 5x16	vite 5x16
18	21054600	1	Führungsstopfen	bolt	Boulon	bullone
19	20054500	1	Scheibe 10,5x18x1,4	washer 10,5	Rondelle 10,5	rondella 10,5
20	21054700	1	Halteprofil+Bürstenstreifen	brush strip	Bande de protection balai	striscia spazzola con supporto
21	21057600	1	Passfeder 8x7x30 VA	featherkey	Ressort d'ajustage	linguetta di aggiustamento

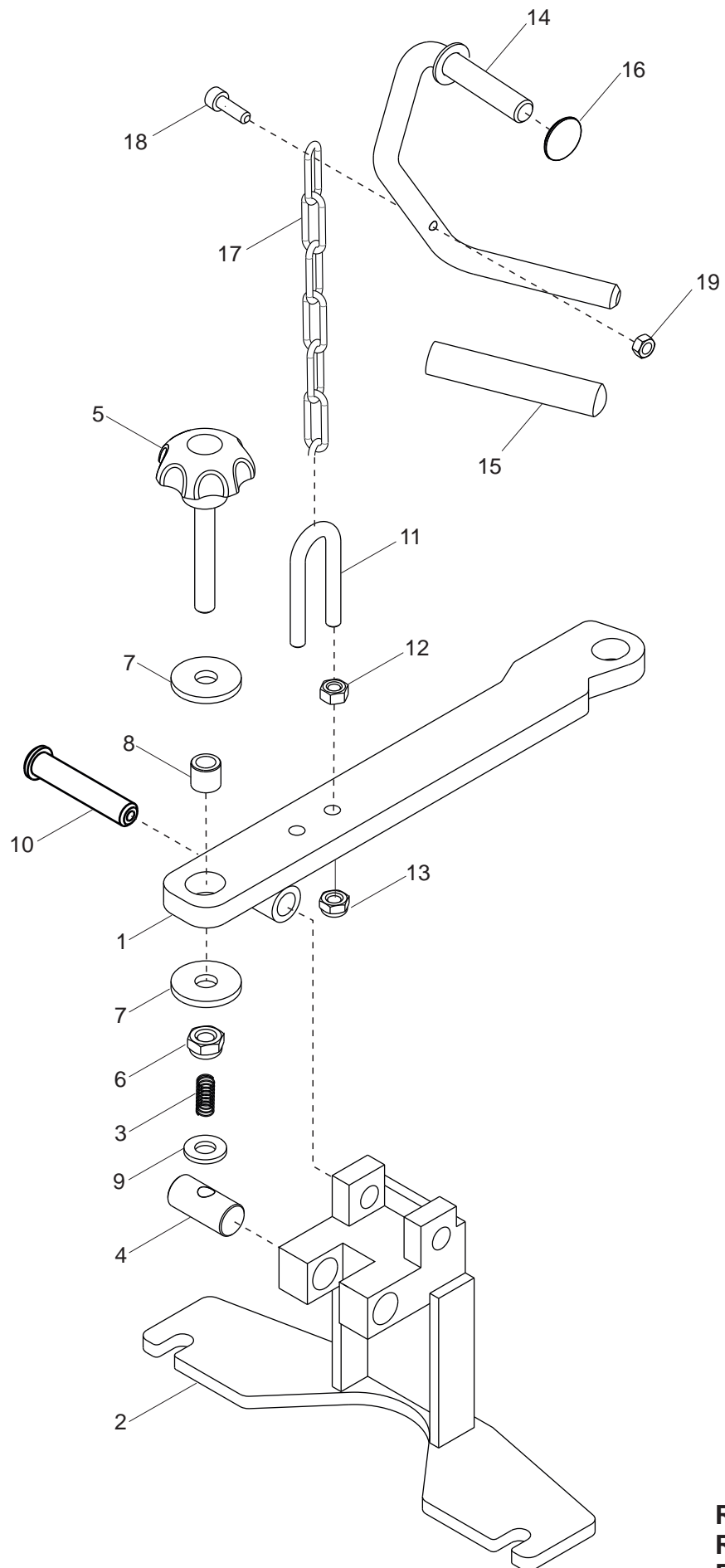

Düsenaufhängung

Pos.	Art. Nr.	Stück	Bezeichnung	Description	Designation	Descrizione
1	21521601	1	Düsenwenkhebel	lever	Levier	leva
2	21521700	1	Düsenhalter	support	Reteneur buse d'aspiration	supporto bocchetta
3	20856100	1	Druckfeder VD-207KA VA	compression spring	Ressort de compression	molla di compressione
4	20801300	1	Gelenk Düsenneigung	articulation	Articulation	giunto
5	20585500	1	Sterngriffschraube M8x55	star wheel screw M8x55	Vis avec poignée étoile M8x55	vite grip a stella M8x55
6	20280500	1	6-Kantmutter M 8 stop	hex.nut M8	Ecrou hexagonal M8	dado essag. M8
7	20277800	2	Scheibe 9x28x3 VA	washer 9x28x3	Rondelle 9x28x3	rondella 9x28x3
8	21528400	1	Distanzbuchse 8x12x11	bush	Buchon d'espacement	boccola
9	20067600	1	Scheibe 8,4x16,0x1,6 VA	washer 8,4	Rondelle 8,4	rondella 8,4
10	21521800	1	Bolzen Gerätedüse	bolt	Boulon	bullone
11	20818300	1	U-Bügel	U-bow	U-archet	staffa-U
12	20002000	1	6-Kantmutter M 6 VZD	hex. nut M 6	Ecrou M 6	dado essag. M 6
13	20070000	1	6-Kantmutter M 6 stop	hex. nut M 6	Ecrou M 6	dado essag. M 6
14	21536500	1	Saugdüsenhebel	lever	Levier	leva
15	20894000	1	Überzug Saugdüsenhebel	lever sheathing	Revêtement de protection	ricoprimento leva
16	20959000	1	Federscheibe mit Kappe D10	washer	Rondelle	rondella
17	50630200	0,35	Kette 3x26 V2A	chain	Chaine	cerniera
18	20061500	1	Zylinderschraube M 5x16 vz	cylindrical head screw M5x16	Vis cylindrique M5x16	vite M5x16
19	20574300	1	6-Kantmutter M 5 VA	hex.nut M5	Ecrou hexagonal M5	dado essag. M5

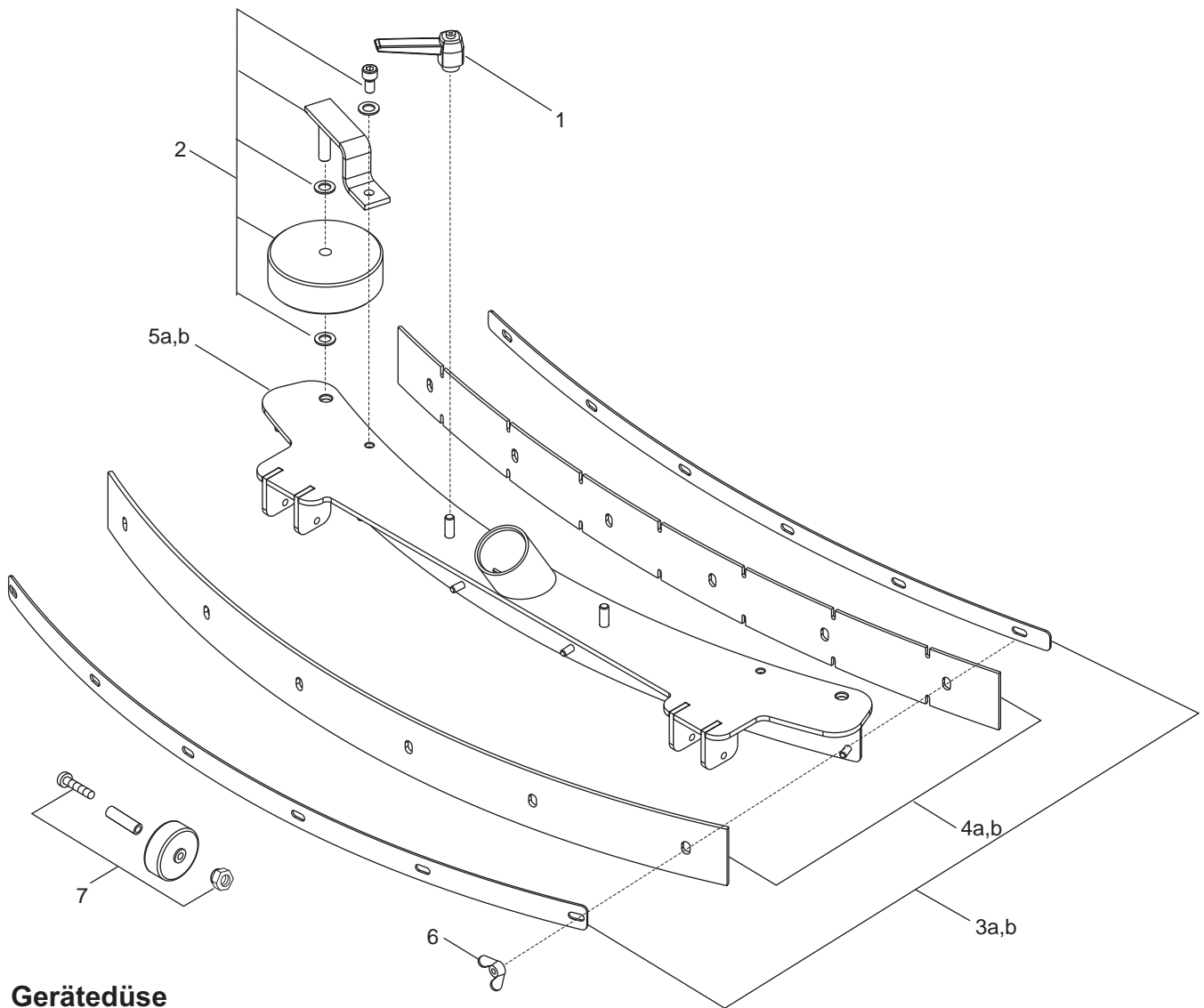

Gerätedüse

Pos.	Art. Nr.	Stück	Bezeichnung	Description	Designation	Descrizione
	20623535		Gerätedüse kpl.43	squeegee tool cpl. 43	Buse d'aspiration 43	ugello aspirante 43
	20623634		Gerätedüse kpl. 55	squeegee tool cpl. 55	Buse d'aspiration 55	ugello aspirante 55
1	20783230	1	Klemmhebel Set	clamping lever set	Sert evier pour fix.	lavetta di fissaggio
2	20622830	2	Abweisrolle niedrig kpl.	low protecting caster	Roulette de protection	ruote di protezione
3a	20621230	1	Klemmleisten Satz 43	clamping strip set 43	Fixation (set) 43	piattina bloccagomma set 43
3b	20620730	1	Klemmleisten Satz 55	clamping strip set 55	Fixation (set) 55	piattina bloccagomma set 55
4a	20621033	1	Sauglippen Satz 43	squeegee blades set 43	Listels set 43	set lamelle 43
4b	20620531	1	Sauglippen Satz 55	squeegee blades set 55	Listels set 55	set lamelle 55
5a	20620902	1	Gerätedüse 43	squeegee tool 43	Buse d'aspiration 43	ugello aspirante 43
5b	20620402	1	Gerätedüse 55	squeegee tool 55	Buse d'aspiration 55	ugello aspirante 55
6	20623130	1	Flügelmutter Set (12 Stück)	nut set (12 pieces)	Ecrou (set-12 pieces)	dado set (12 pezzi)
7	20442433	2	Gummirolle	roller	Roulette	rotella

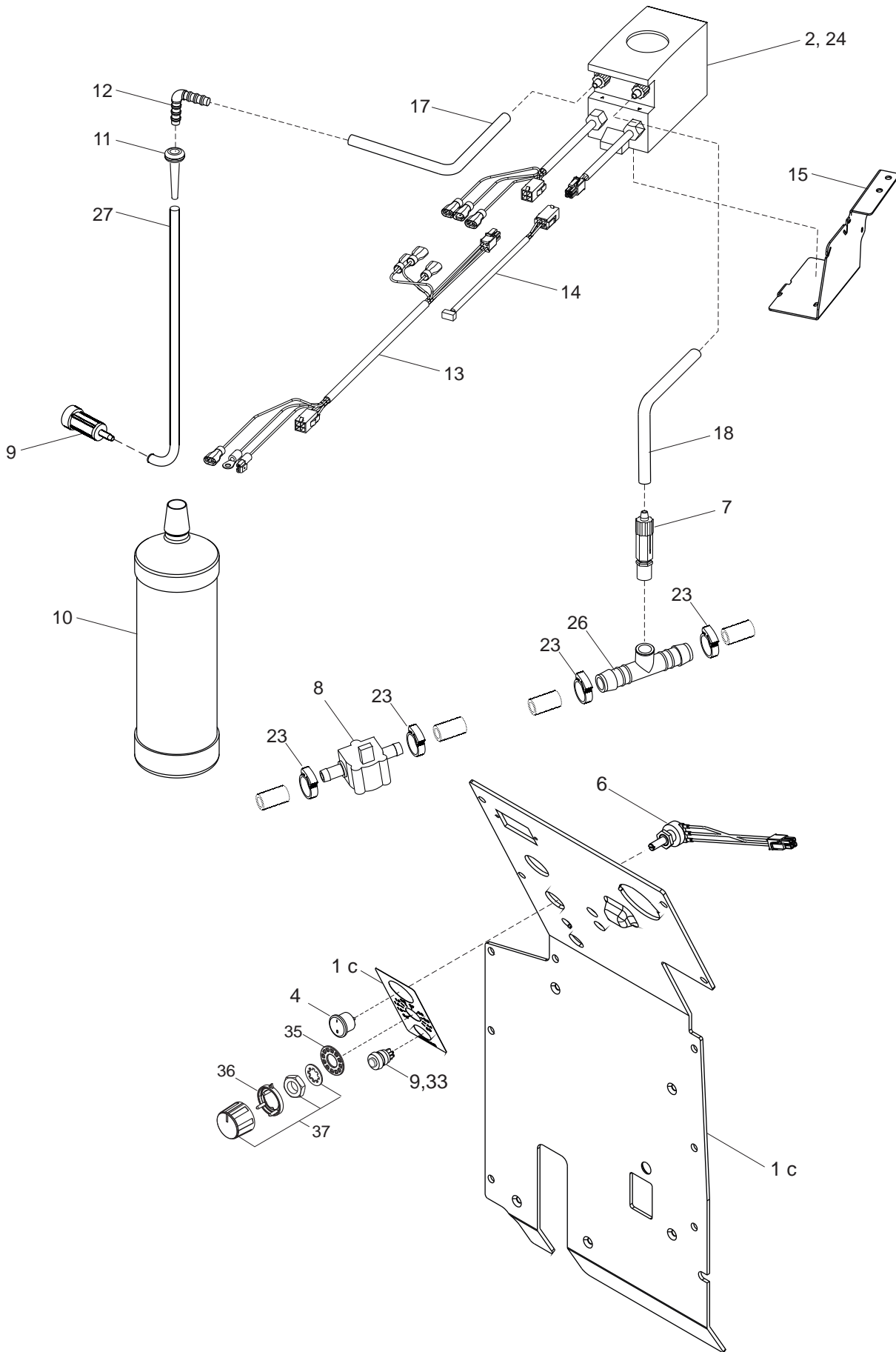

Chemiedosierung (Optional)

Pos.	Art. Nr.	Stück	Bezeichnung	Description	Designation	Descrizione
1c	21541200	1	Rückwand B Chemie	electric box B	electric box B	electric box B
	70108300	1	Aufkleber Chemiedosierung	sticker	Autocollant	sticker
2	20970600	1	Chemie-Pumpe	pump	Pompe	Pompa
3	20369100	1	Druckknopfschalter	switch	commutateur	commutatore
4	21044000	1	Wippschalter rund	interrupter	interrupteur	interruttore
5	21168830	1	Potentiometerknopf	knob	bouton	manopola
6	21168730	1	Potentiom.100 KOhm	potentiometer	Potentiomètre	potenziometro
7	20970800	1	Rückschlagventil	retention valve	valve de retenue	valvola antiritorno
8	20970700	1	Durchlaufmesser	flow indicator	débitmètre	flussometro
9	20405300	1	FW-Filter	filter	filtre	filtro
10	21041700	1	Flasche PA leer 1L	container	bidon	bidone
11	21046400	1	Knickschutzülle	grommet	Buchon pour cable	passacavo
12	21041800	1	Verbindungsstutzen	hose nozzle	Tubulure fileté	beccocio tubo flessib.
13	21539800	1	Kabel Chemiedosierung	cable	Câble	cavo
14	21041400	1	Kabel Pumpe-Durchlaufmesser	cable	Câble	cavo
15	21524201	1	Halter Chemiepumpe	pump holder	support pour pompe	supporto per pompa
17	50986300	2,0 m	PVC-Schlauch transp. 5x1,5	hose	Tuyau	tubo flessibile
18	50986300	0,7 m	PVC-Schlauch transp. 5x1,5	hose	Tuyau	tubo flessibile
23	20596500	4	Schlauchklemme D17-18,5	hose clamp	Collier	fascetta per tubi flessibili
26	21047301	1	T-Stück 12	hose nozzle	Tubulure fileté	beccocio tubo flessib.
27	50986300	0,270 m	PVC-Schlauch transp. 5x1,5	hose	Tuyau	tubo flessibile
33	20616000	1	Schutzkappe	protective cap	Capuchon de protection	cappuccio di protezione
35	21341900	1	Rastscheibe	locking disc	disque de blocage	disco di bloccaggio
36	21342000	1	Rastfeder	locking spring	ressort de blocage	molla di bloccaggio
37	21168830	1	Potentiometer-Knopf	potentiometer button	Bouton potentiomètre	manopola potenziometro

Änderungen im Zuge technischer Verbesserungen sind vorbehalten !
We reserve the right to effect modifications within the framework of technical progress !
Sous réserve de modification dans le cadre des développements techniques !
Essendo la nostra un'impresa a carattere innovativo, ci riserviamo la possibilità di apportare modifiche tecniche !

G. Staehle GmbH u. Co. KG
columbus Reinigungsmaschinen
Mercedesstr. 15
D - 70372 Stuttgart
Telefon +49(0)711 / 9544-950
Telefax +49(0)711 / 9544-941

info@columbus-clean.com
www.columbus-clean.com

71004000

columbus